

Operator Manual

Trimmer TR 85

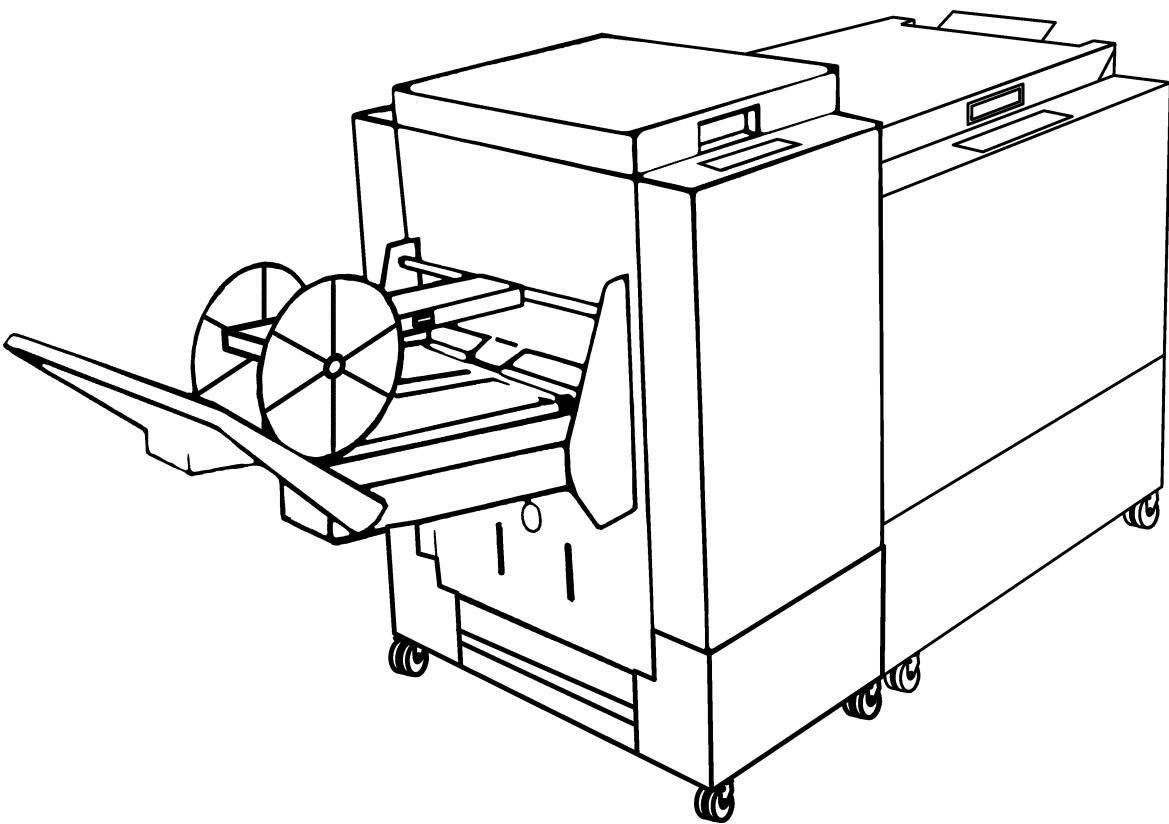

February 2001

Part No. 75671

Table of contents

1. Introduction	Page
1.1 Operational safety	1-1
2. Getting to know the TR 85	
2.1 Main components	2-1
2.2 Control panel	2-3
3. Operator instruction	
3.1 Switching on the TR 85 Power	3-1
3.2 Setting up the TR 85	3-1
3.3 Adjusting the cutting margin	3-2
3.4 Status indicators	3-1
4. Problem solving	
4.1 Clearing jams	4-1
4.2 Troubleshooting table	4-3
5. Specifications	
5.1 Specifications	5-1

1. Introduction

1.1 Operational safety

Attention to the following notes ensures the continued safe operation of your equipment.

Always connect the equipment to a properly grounded power source receptacle. In doubt, have the receptacle checked by a qualified electrician.

WARNING: Improper connection of the equipment grounding conductor can result in electrical shock.

Always follow all warnings marked on, or supplied with, the equipment.

Always locate the equipment on a solid support surface with adequate strength for the weight of the machine.

Always exercise care in moving or relocating the equipment.

Always keep magnets and all devices with strong magnetic field away from the machine.

Never use a ground adapter plug to connect the equipment to a power source receptacle that lacks a ground connection terminal.

Never attempt any maintenance function that is not specifically described in this documentation.

Never remove the covers or guards that are fastened with screws.

Never install the unit near a radiator or any other heat source.

Never override or “cheat” electrical or mechanical interlock devices.

Never operate the equipment if you notice unusual noises or odours. Disconnect the power cord from the power source receptacle and call your customer service engineer to correct the problem.

2. Getting to know the TR 85

Take a few minutes to become familiar with the main components of the TR 85.

2.1 Main components

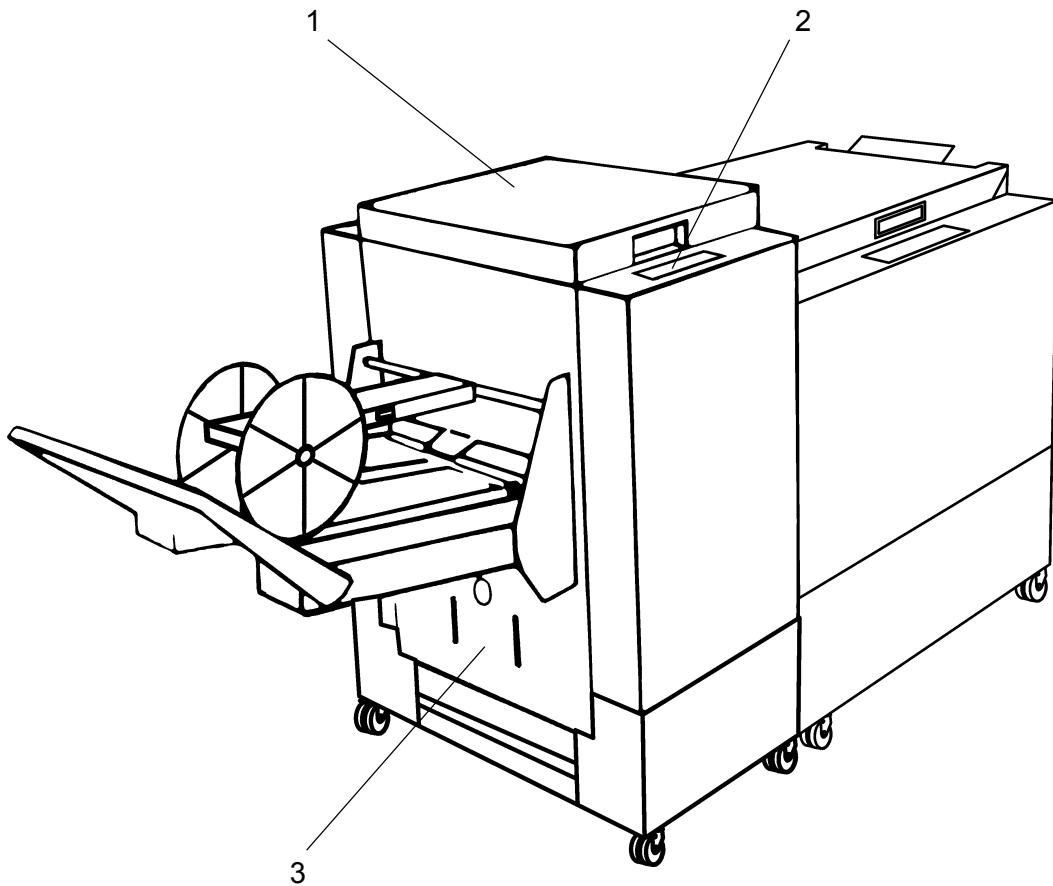

1. Top cover
2. Control panel
3. Scrap paper bin

2.1 Main components, continues

The TR 85 interior has parts that you will come in contact with if paper jams occur.

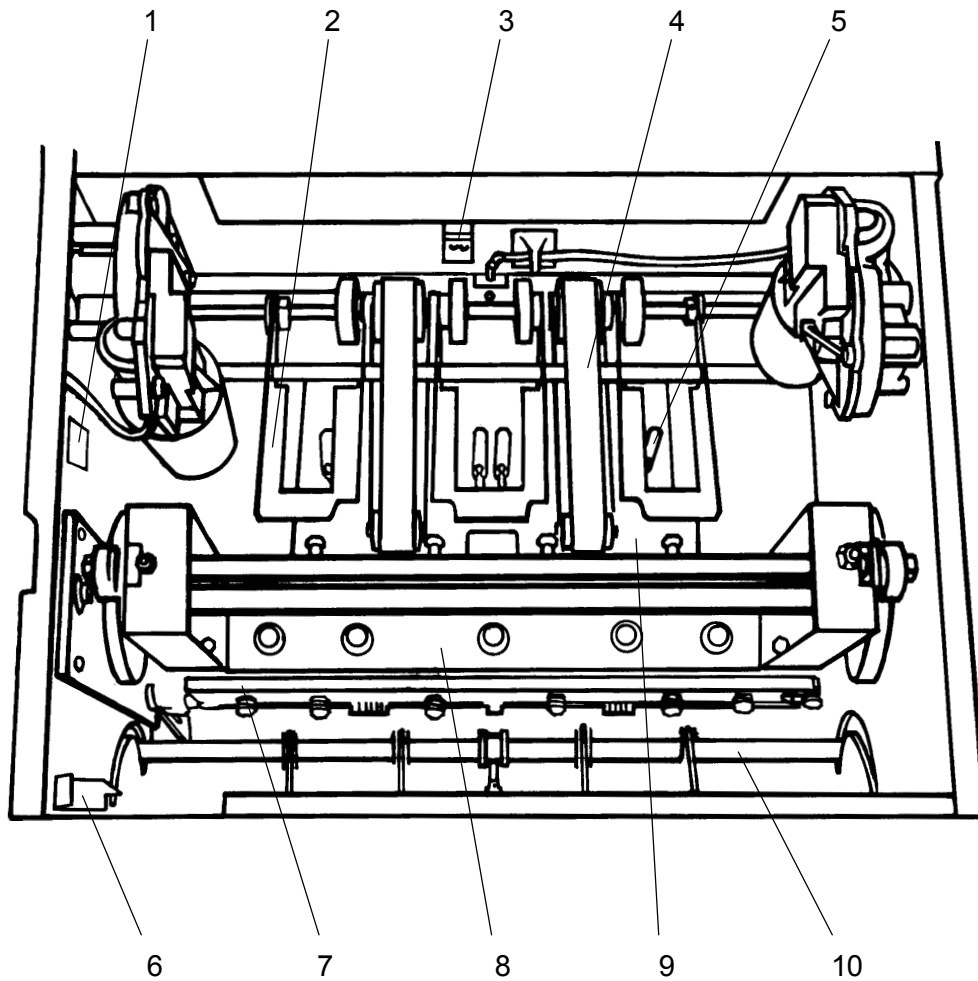

- | | |
|-----------------------------|-----------------------|
| 1 Total set counter | 6 Infeed latch |
| 2 Exit compressing brackets | 7 Upper knife |
| 3 Outfeed latch | 8 Upper knife beam |
| 4 Transport belt | 9 Deck plate |
| 5 Trimmer stop | 10 Input roller shaft |

2.2 Control panel

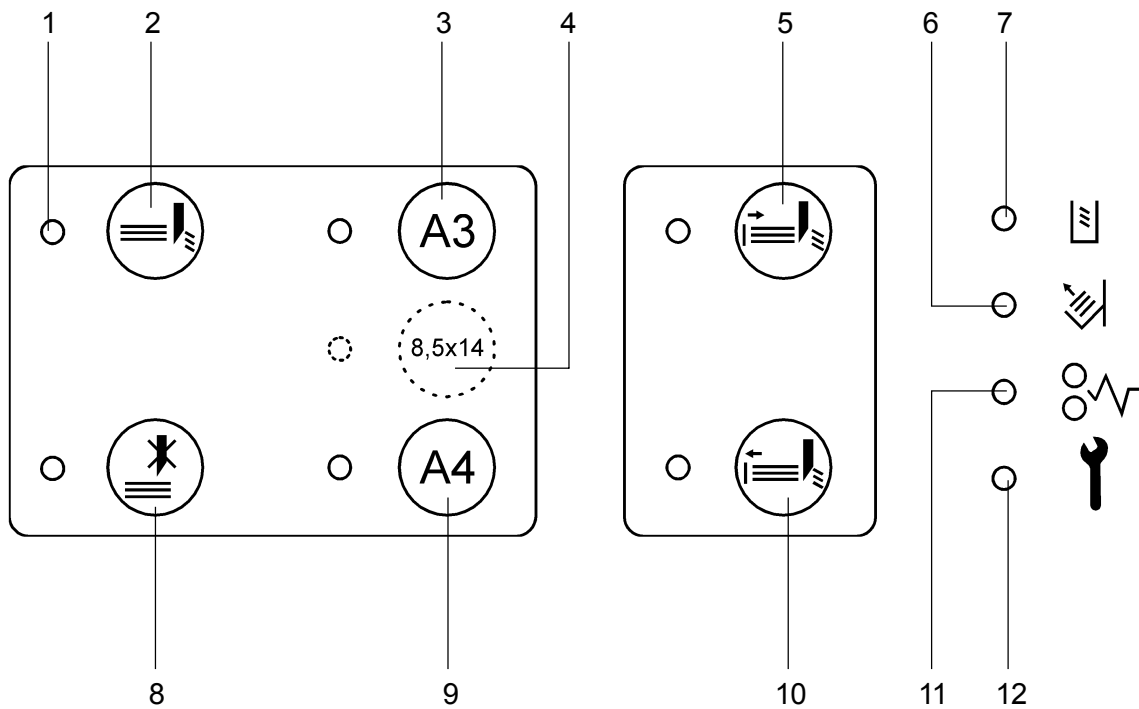

- | | | | |
|----|--------------------------|-----|--------------------------------|
| 1. | Mode indicator LED | 7. | Scrap paper bin full indicator |
| 2. | Trimmer mode | 8. | By-pass mode |
| 3. | A3 / 17" size | 9. | A4 / 11" size |
| 4. | 14" size (60Hz models) | 10. | Increased cutting margin |
| 5. | Decreased cutting margin | 11. | Paper jam indicator |
| 6. | Stacker full indicator | 12. | Dull knife indicator |

3. Operator instruction

This chapter explains the operation of the TR 85 when operating on-line with the SR 85.

3.1 Switching on the TR 85 power

1 Plug the SR 85 into the wall outlet.

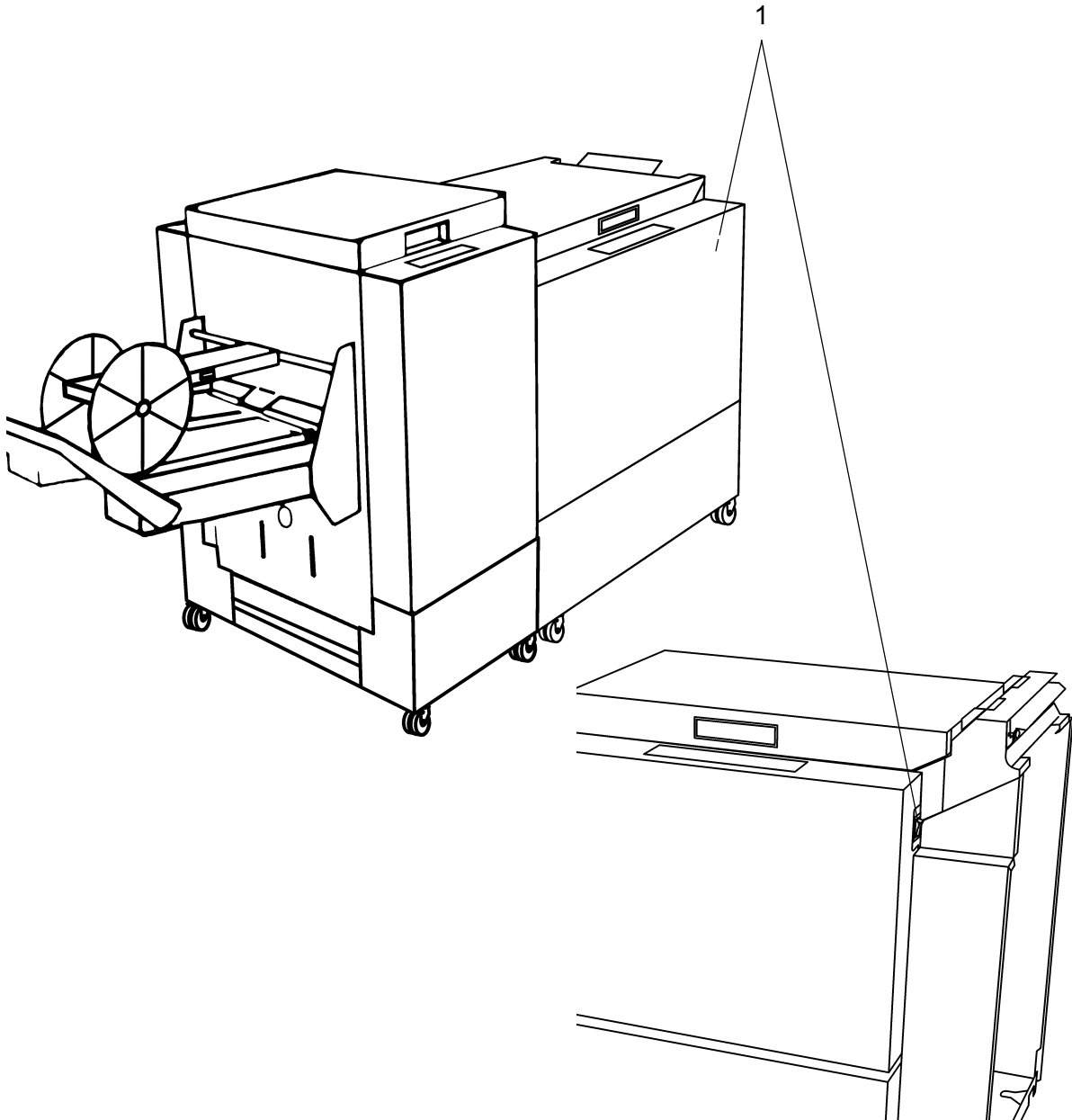

2 Set ON/OFF switch (1) on SR 85 to ON position. The TR 85 is automatically set to by-pass mode.



3.2 Setting up the TR 85

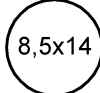

The TR 85 has a pre-set cutting margin of 4mm when selecting a paper size button on the operating panel. This can be increased or decreased by pressing the adjustment buttons. The maximum cutting is 10mm.

Select a paper size

-  1 Press this button for A3/17" sheet size.
-  2 Press this button for A4/11" sheet size.
-  3 Press this button for 14" sheet size.

NOTE: Allow 10 seconds adjusting time

Select operating mode

-  4 Press this button for trimmer mode
-  5 Press this button for by-pass mode

NOTE: If a jam occurs in the TR 85, it will automatically switch to by-pass mode. The control panel will however still be indicating trimmer mode. When the jam is cleared and top cover is closed, the TR 85 will return to trimmer mode.

3.3 Adjusting the cutting margin

The pre-set sizes are set for an approximately 4mm cut of the middle sheet of the booklet. This can easily be adjusted by pressing the adjustment buttons to increase or decrease the cutting margin. By pressing and holding the button down the trimmer stop will move continuously, if pulsing the button the trimmer stop will move for approximately 0,5mm.

Adjustments

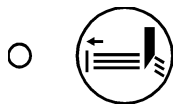

1 Press this button to increase the trim

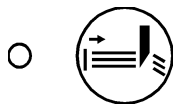

2 Press this button to decrease the trim

NOTE: Use the below table as a reference when setting the cutting margin.

No. of sheets per booklet	Amount of trim	Adjustment procedure
2 through 5 sheets.	4 mm.	Default setting is 4 mm. No adjustment required.
6 through 10 sheets.	5 mm.	Press the adjustment button two times to increase the trim.
11 through 15 sheets.	6 mm.	Press the adjustment button four times to increase the trim.
16 through 20 sheets.	7 mm.	Press the adjustment button six times to increase the trim.

3.4 Status indicators

When a status indicator comes on it does not usually require a service call. After the condition is corrected, you may continue production.

Indicators

-  1 Scrap paper bin full. Empty scrap paper bin.

-  2 Belt stacker full. Empty belt stacker.

-  3 A paper jam has occurred in the trimmer paper path. See section **4 Problem solving** for reference.

-  4 The trimmer knife has taken too long to complete the trimming cycle. Open and close the top cover. If the indicator light stays on, call your service representative for service.

4. Problem solving

This chapter explains how to clear a jam that may occur during the operation of the TR 85. After clearing a jam, close the top cover and continue the production.

4.1 Clearing jams

The upper trimmer blade on the TR 85 is protected by a knife protection plate that moves away during the cutting stroke. Jams can occur in the input area or the exit area.

Input area jam clearance

1 Lift up the input roller shaft (1).

2 Remove the jam in the input area.

3 After the jam is removed, lift up the latch (2) and place the input roller shaft into operating position.

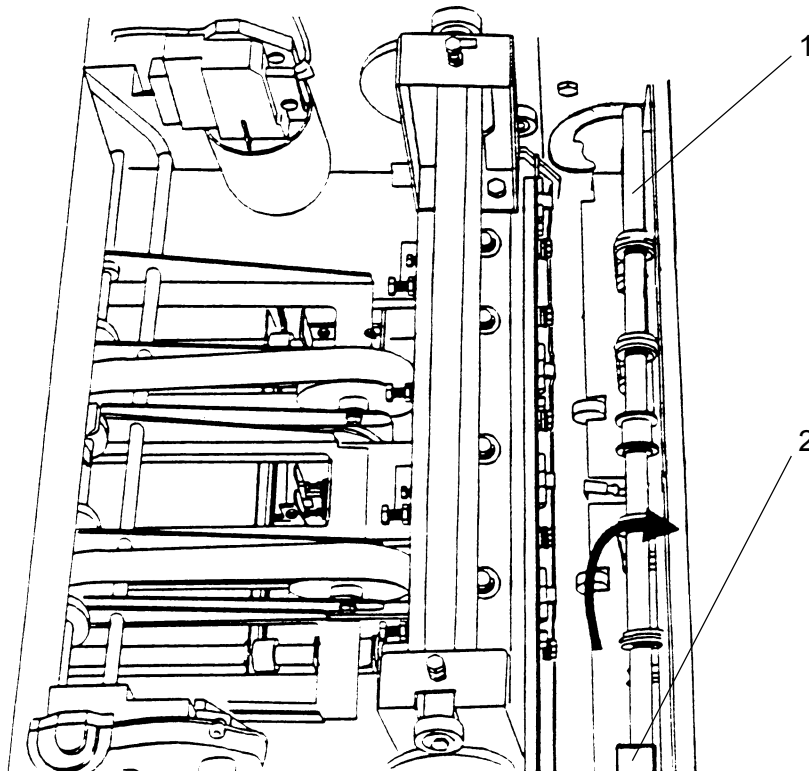

4.1 Clearing jams, continues

Exit area jam clearance

4 Lift the exit compressing brackets (3).

5 Secure them under the latch (4).

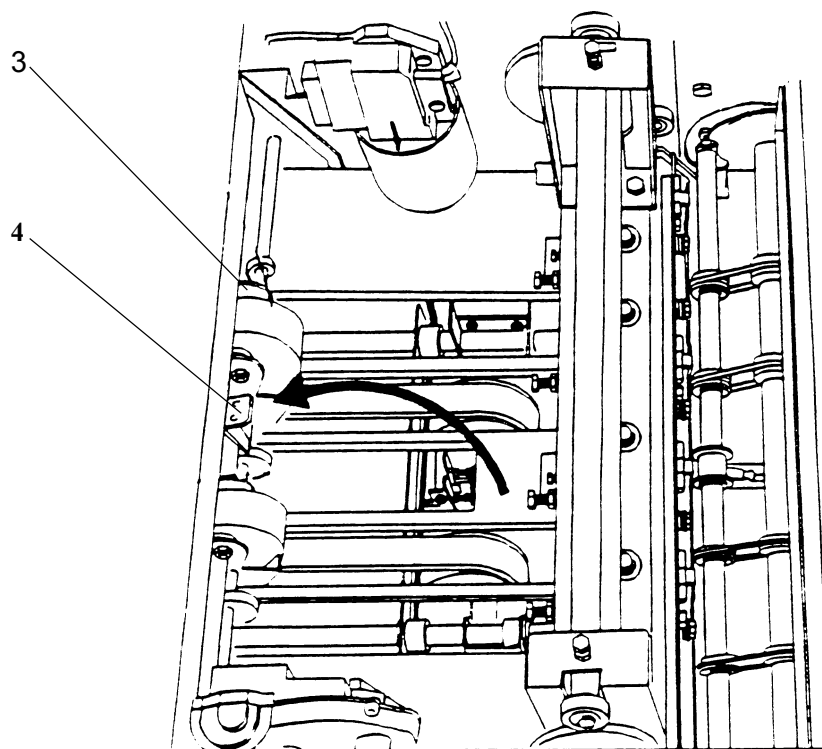

6 Remove the jam from the exit area.

7 After the jam is removed, lift up the latch (4) and place the compressing brackets in operating position.

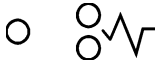

4.2 Troubleshooting table

Use the below table as reference to solve problems that may occur when operating the TR 85.

PROBLEM	POSSIBLE CAUSE	ACTION
Trimmed scraps are coming out of the TR 85 and on to the belt stacker.	Trim width too small.	Increase the trimming.
Scrap paper bin indicator stays on after bin has been emptied. 	A trimmed piece may be caught in paper chute.	Remove piece from paper chute.
The jam indicator light stays on after jam is cleared. 	The input roller shaft may be in upper clearance position. The exit roller and compressing brackets may be in upper clearance position.	Release the input roller shaft latch and place the shaft in operating position. Release the exit compressing brackets latch and place them in operating position.
The trimmer knife indicator light is on. 	The booklet may be too thick.	Check that the booklet does not contain more than 20 sheets of 80 gsm (20 lbs) paper.

5. Specifications

5.1 Specifications

	Trimmer TR 85
Paper weight minimum	64 gsm / 17 lb.
Paper weight maximum	163 gsm / 43 lb.
Minimum paper size width	210 mm / 8,3"
Maximum paper size width	300 mm / 11,8"
Minimum paper size length	279 mm / 11"
Maximum paper size length	432 mm / 17"
Capacity	20 sheets of 80 gsm (20lbs) 80 pages
Speed	2 A4 / 8,5" x 11" sheets from the printer 800 books / hour 2 A3 / 11" x 17" sheets from the printer 500 books / hour
Preset programmes 60 Hz machines	11" paper size 14" paper size 17" paper size
Preset programmes 50 Hz machines	A3 paper size A4 paper size
Output tray	Conveyor belt stacker
Length (stacker folded up)	1227 mm / 48,307"
Length (stacker folded down)	1732 mm / 68,189"
Height	880 mm / 34,646"
Width	595 mm / 23,425"
Weight	65 kg
Voltage	220 V/230 V/240 V, 50 Hz 115 V, 60Hz